



User Manual

Model: H60B0

Govee Uplighter Floor Lamp

Safety Instructions

IMPORTANT SAFETY INSTRUCTIONS

When using products, basic precautions should always be practiced including the following:

READ AND FOLLOW ALL SAFETY INSTRUCTIONS.

- Use the product with the provided power adapter only.
- The product is not waterproof. Do not expose it to areas susceptible to water splashes or water drops.
- The internal light sources cannot be replaced. If it breaks, the product should be replaced. Do not allow children to install the floor lamp alone. Do not disassemble or modify the device and its accessories.
- Avoid installing the device near potentially dangerous sources or heat sources (e.g. candles, liquid-filled objects.)
- The working temperature should be between 14°F to 104°F (-10°C to 40°C).
- Store the product in places where the temperature is within -4°F to 140°F (-20°C to 60°C) if you do not plan to use it for a long time.
- Do not install the product with a dimming driver.
- This product is equipped with a microphone, which is only used to capture the rhythm of the sound.
- CAUTION-The product is not a toy. Children and the disabled should use it under adult supervision.

SAVE THESE INSTRUCTIONS

Introduction

Thanks for choosing Govee Floor Lamp! This product is suitable for the living room, bedroom, and home office. As your "ambiance assistant", its brightness and colors can be adjusted via Govee Home App. With a variety of preset scenes and modes, you can easily switch the effects to your liking and unleash your creativity.



What You Get

Item	Quantity
Floor Lamp (Lamp Base × 1, Lamp Pole × 4, Lamp × 1)	1
Power Adapter	1
User Manual	1
Service Card	1

At a Glance

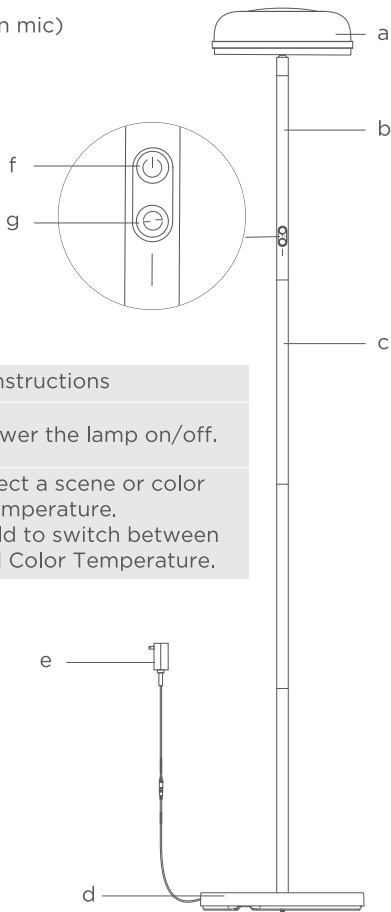
- a. Lamp Head (with a built-in mic)
- b. Lamp Pole (with buttons)
- c. Lamp Pole
- d. Lamp Base
- e. Power Adapter
- f. On/Off Button
- g. Scene Button



Buttons	Instructions
 On/Off Button	Press to power the lamp on/off.
 Scene Button	Tap to select a scene or color temperature. Tap and hold to switch between Scenes and Color Temperature.

Installing Your Device

Step 1

Connect the connectors before plugging the fixture into a power source to confirm whether it lights up. If an abnormality is found, please contact customer service in time.

Step 2

If the lamp works well, disconnect the power adapter and install based on the pictures.

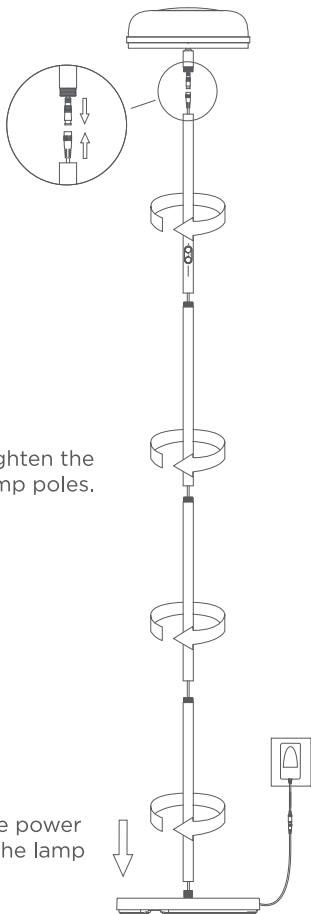

Tips:

1. Adjust the lamp head angles to light up your ceiling. The lamp head is adjustable at 60° in the vertical direction.

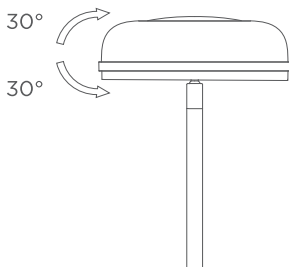

2. Three slots are provided to organize the cords in the lamp base, please fix the cords in proper locations as needed.

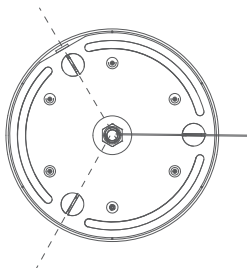

Pairing Your Light with Govee Home App

- A Wi-Fi router supporting the 2.4GHz and 802.11b/g/n bands is required. 5GHz is not supported.



1. Download Govee Home App from the App Store (iOS) or Google Play (Android). Log in with your account. New users need to create an account.
2. Turn on the Bluetooth on your smartphone.
3. Open the app, tap the “+” icon in the top right corner and search for “H60B0”.
4. Tap the device icon and follow the on-screen instructions to complete pairing.

Matter Guide

Matter User Guide

1. How to use Matter

Step 1

Find the Matter QR code or device number on the product or on the “Device Settings” page in Govee Home App.

Step 2

Turn on the Bluetooth on your smartphone and keep it on.

Step 3

Download and open the app that supports Matter such as Amazon Alexa/Google Home/Apple HomeKit, etc.

Step 4

Use the device number or QR code on the device in the app to complete the network connection with Matter for the device.

2. Important

You will need to complete the network connection of apps that support Matter (e.g. Amazon Alexa/Google Home/Apple HomeKit etc.) within 15 minutes after the product is powered on when using Matter for the first time.

An IPv6 network is required.

Changing the network may cause Matter to malfunction.

If the product cannot connect to the app, Long press the power button on the lamp pole and press the Scene Button 4 times consecutively to restore factory settings. After that, try connecting again later.

If you need to change the network when using Matter, close Govee Home App and power off the device. Then, power back on and complete the network connection of apps that support Matter (e.g. Amazon Alexa/Google Home/Apple HomeKit etc.) within 15 minutes.

Controlling the Lamp with Your Voice

1. Open the app, then tap the device icon to enter the control page.
2. Tap the settings icon in the top right corner.
3. Select "User Guide" and follow the on-screen instructions to control the device using your voice.

Specifications

Model	H60B0
Power Adapter Input	AC 100-240V 50/60Hz (US Plug) AC 200-240V 50/60Hz (EU&BS Plug)
Lamp Input	24VDC 1A
Lumens (Lower Light)	1000 lm
Ripple Effect Displaying Technology	RGBWW
Sidelight Displaying Technology	RGBIC
Lower Light Displaying Technology	WW
Control Methods	Physical Buttons, Govee Home App, Voice Control
Working Temperature	-10°C-40°C / 14°F-104°F

Troubleshooting

1. Cannot connect to Govee Home App.
 - a. Check if the lamp has been powered on.
 - b. Check if your smartphone's Bluetooth has been turned on or try connecting the lamp to another smartphone.
 - c. Ensure that your smartphone is near the lamp when connecting for the first time.
 - d. If the problem persists, go to the "Device" page to delete the device and follow the previous instructions to reconnect.

2. Cannot connect to Wi-Fi.
 - a. Check if the lamp has been powered on.
 - b. Do not skip connecting to Wi-Fi during the pairing process.
 - c. Ensure that your Wi-Fi router is 2.4GHz capable (5GHz is not supported).
 - d. Ensure that you entered the correct Wi-Fi password during the Wi-Fi connection process.
 - e. Shorten the distance between the lamp and the Wi-Fi router to less than 50ft, then try reconnecting.
 - f. Use another smartphone to pair with the lamp to check if your Wi-Fi network is working.
3. Cannot pair or connect with Alexa or Google Assistant.
 - a. Check if the lamp has been powered on.
 - b. Do not skip connecting to Wi-Fi during the pairing process.
 - c. Ensure that your Wi-Fi router is 2.4GHz capable. 5GHz is not supported.
 - d. Ensure that you entered the correct Wi-Fi password during the Wi-Fi connection process.
 - e. Shorten the distance between the lamp and the Wi-Fi router to less than 50ft, then try reconnecting.
 - f. Use another smartphone to pair with the lamp to check if your Wi-Fi network is working.
4. The lamp does not display the selected color fully or some LED beads do not light up.
 - a. Please contact Customer Support for a rapid product replacement.
5. Reset to factory settings
 - a. Long press the power button on the lamp pole and press the Scene Button 4 times consecutively to restore factory settings.

Disassembly Tip:

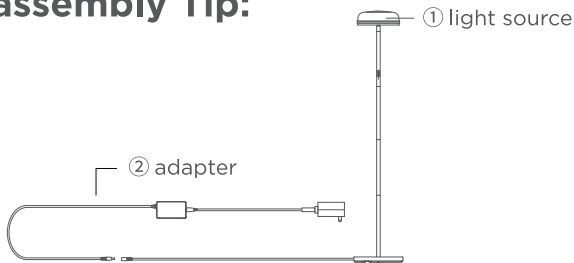

The product is divided into two parts: (1) a light source and (2) an adapter. By detaching the output terminal of the adapter, you can easily remove the light source or the adapter.

Customer Service

 Warranty: 12-Month Limited Warranty

 Support: Lifetime Technical Support

 Email: support@govee.com

 Official Website: www.govee.com

 @GOVEE  @goveeofficial  @govee.official

 @GoveeOfficial  @GOVEE



Govee Home App

For FAQs and more information,
please visit: www.govee.com